INSTRUCTIONS

IMPORTANT SAFEGUARDS

When using electrical equipment, basic safety precautions should always be followed including the following:

1. **READ AND FOLLOW ALL SAFETY INSTRUCTIONS**
2. Disconnect power before performing work on electrical equipment.
3. Use caution when servicing batteries.
4. Equipment should be mounted in locations and at heights where unauthorized personnel will not readily subject it to tampering.
5. The use of accessory equipment not recommended by BeLuce Canada Inc., may cause an unsafe condition, and will void the unit's warranty.
6. Do not use this equipment for other than its intended purpose.
7. Servicing of this equipment should be performed by qualified service personnel.
8. **SAVE THESE INSTRUCTIONS!**

INSTALLATION

WALL MOUNT:

1. Remove all screws on the front cover / faceplate and then remove the cover.
2. Mount the RM SIGN securely in place using the wall mounting diagram. (figure 2)
3. Use a rated watertight conduit hub(s) to connect the conduit to the enclosure. (optional)
4. Connect supply per diagram provided. Insulate unused wire!
CAUTION! Failure to insulate unused wire may result in a shock hazard or unsafe condition as well as equipment failure.
5. Install the require RM face as needed.
6. Replace the cover and tighten the screws by hands only.
7. Turn on the AC voltage supply.

CEILING/ END MOUNT:

1. If the installed face on the sign is not the one in need, remove all screws on the cover, then remove the face and cover. (figure 1)
2. Install the required face and replace the cover with the required face.
3. Hand tighten the cover. **DO NOT** over tighten!
4. Connect supply per diagram provided. Insulate unused wire!
CAUTION! Failure to insulate unused wire may result in a shock hazard or unsafe condition as well as equipment failure.
5. Secure canopy in place – supplied mounting holes fit most standard electrical boxes. If not use spider plate supplied in the package.
6. Turn on the AC line voltage supply and the exit should light up.

SELF-POWERED:

1. Remove all screws on the front cover, then remove the cover.
2. Plug battery into the circuit board. (figure 3)
3. If wall mount, follow **WALL MOUNT** step 2 to step 8.
4. If ceiling/end mount, then go to **CEILING/ END MOUNT**.

Figure 1
Ceiling/End Mount

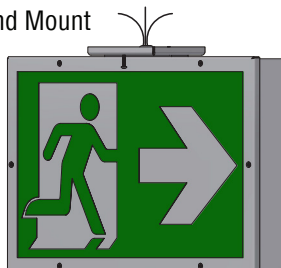

Figure 2
Wall Mount

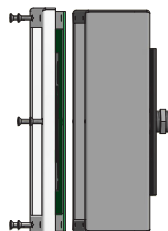
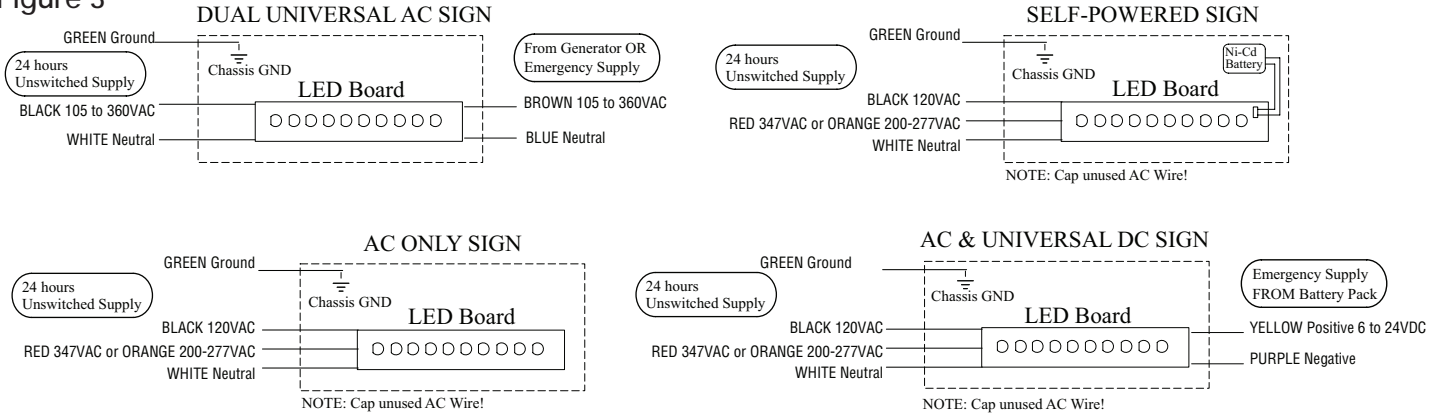

Figure 3



MAINTENANCE

1. The equipment is to be repaired whenever the equipment fails to operate as intended during the duration test. Written records of test results and any repairs made must be maintained. BeLuce Canada Inc. strongly recommends compliance with all Code requirements.
2. The lamps listed herein when used according to the instructions with this unit are in accordance with the requirements of CSA Standard C22.2, No. 141 – Unit Equipment for Emergency Lighting.
3. Clean exit face(s) on a regular basis.

NOTE: The servicing of any parts should be performed by qualified service personnel only. The use of replacement parts not furnished by BeLuce Canada Inc., may cause equipment failure and will void the warranty.

TROUBLESHOOTING

LEDS DO NOT COME ON AT ALL

1. Check AC supply be sure unit has 24 hour AC supply (unswitched).
The AC supply must be at least 80% of nominal (96V on a 120V line) for equipment to function normally. At lower voltages the LED lamps will begin to glow dimly until the source voltage drops below the full “turn on” point.
NOTE: This condition may also be caused by incorrectly connecting an AC Volt supply line to the lead.
2. Check all AC connections
3. AC supply is OK, replace LED Board Assembly.

IF THE EMERGENCY LIGHTING FIXTURE IS EXPERIENCING ONE OF THE FOLLOWING PROBLEMS:

- The LED indicator is off or displaying the wrong status.
- The LED strip is on during AC power, but there is no emergency backup function.
- The LED strip is on, but the battery is not charging (battery voltage is low).

PERFORM A HARD RESET ON THE BATTERY AND CHARGER BOARD Steps to Perform a Hard Reset:

1. **Disconnect AC Power:** Turn off the AC power supply to the emergency lighting fixture.
2. **Unplug the Battery:** Safely disconnect the battery pack from the charger board.
3. **Wait for 10 Seconds:** Allow the system to completely discharge by waiting a minimum of 10 seconds.
4. **Reconnect Power:** Plug the battery pack back into the charger board.
5. **Restore the AC power** to the fixture.
6. **Verify the Reset:**
 - I. Check that the LED indicator is functioning correctly.
 - II. Ensure that the battery is charging and the emergency backup function is operational.

NOTE: If the issue persists after performing the hard reset, further inspection of the fixture or professional assistance may be required.

SAVE THESE INSTRUCTIONS